

LD43DR



Miniature Deep Recessed LED Uplight

Data sheet

The LD43DR has a very deep recessed LED position with a small aperture, resulting in an uplight with little or no glare. The trade off is a beam which is quite hard on the edges, but makes it ideal for lighting doorways or narrow corridors.

Key Features

- LED and lens assembly deep recessed within a matt black anodised body for reduced glare
- Only available with a narrow 12° optic due to the size of the aperture
- No visible fixings. Options include spring fixing clips or O-rings and a first fix sleeve
- Can be used as an uplighter or downlighter
- Integral anti wicking barrier increases protection against moisture ingress due to incorrect IP rated cable connections
- Optional glare shield accessory for even less glare
- Range of bezel finishes
- Not designed for permanent submersion, please use our LD242A, LD41, and LD60.
- Available with Switch, 0-10V, DMX, Dali or Mains dimmable drivers

Specification

Applications



Beam Angles

12°

LED type

1 x Cree XPG2

Colour temperature

2700K** / 3000K | 5000K

Drive Current (mA)	350	500	700	350	500	700
LED power* (W)	1.2W	1.7W	2.4W	1.2W	1.7W	2.4W
CRI (typical)	93	93	93	75	75	75
Forward voltage (V) ₁₀₀	3.0V	3.2V	3.4V	3.0V	3.2V	3.4V
Delivered lumens** (L ₁₀₀)	75	103	137	91	124	166
Lumens per circuit watt	63	61	57	76	73	69

LED lifetime (to 70% lumen maintenance) 50,000hrs at a max ambient temperature of 35°C (if specifying fitting in ambient temperatures of up to 45°C run at 500mA max, LD43DR-500)

Materials

Matt black anodised aluminium body, Machine finish 316 stainless steel bezel (other options available)

Glass

3.3mm thick borosilicate

Wiring

Comes pre-wired with 2 core 100mm lead, can be specified with up to 10m at extra cost

IP rating

IP68 - Not for permanent submersion (for permanent submersion applications use LD242A)

*LED wattage includes losses associated with using an 85% efficient driver

** 2700K lumen output is 12% lower than the 3000K figure listed

4000K lumen output is 14% higher than the 3000K figure listed (80 CRI)

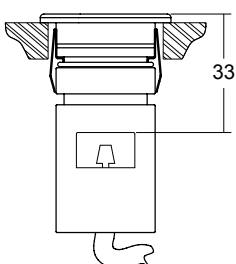

Product: LD43DR-700/LW/W/NB



LD43DR



Miniature Deep Recessed LED Uplight

Data sheet

Dimensions and Fixing Options

/SC - Spring clip fixing

Useful for plinth or downlight applications

/480 - O-rings and sleeve

A more robust and water tight method of fixing, for in ground applications

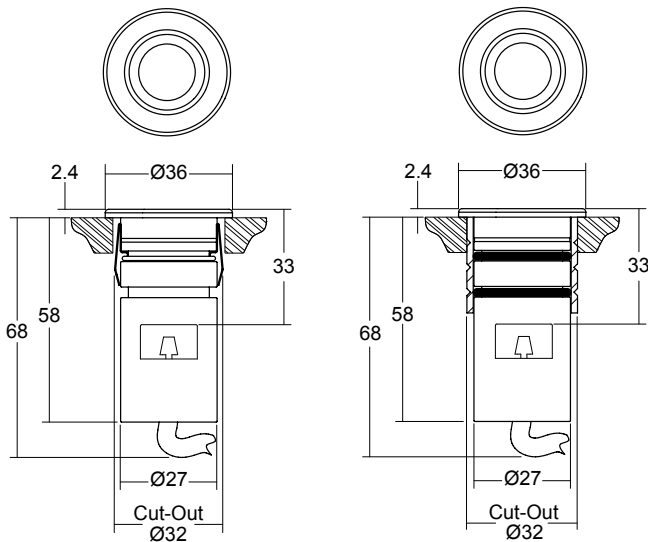

(Dimensions in mm)

/480GT - Ground tube

The in-ground tube has been designed for applications where a recessed uplighter is required in soil or gravel surfaces. The tube can be buried with the necessary wiring, and then the fitting installed after the landscaping work has been completed. It is supplied with the fixing sleeve bonded into the tube, and can be cut down on site.

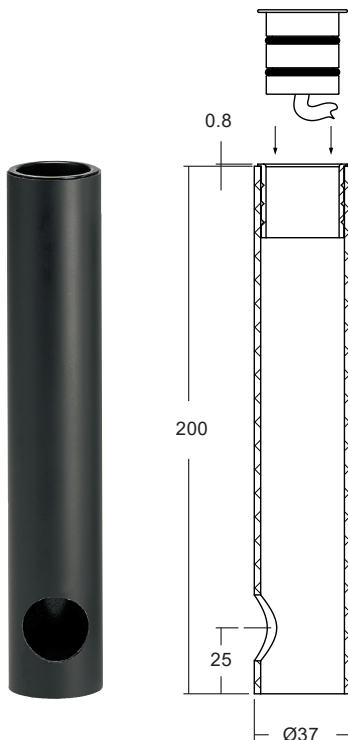

Accessories

/GS - Glare shield

An optional glare shield is available to further reduce glare from the LED and optic. This is useful in narrow details where people are going to be directly over the fitting. This does not reduce the light on the lit surface (wall) but will cut out some light onto the ceiling.

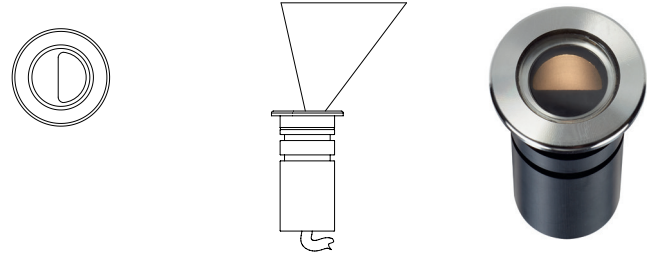

Order Codes and Options

Product code	LED colour	Lens angle	Finish	Accessory	Fixing
LD43DR- 350 - 500 - 700	<input type="text"/>	<input type="text"/>	<input type="text"/>	<input type="text"/>	<input type="text"/>

Example: LD43DR-700 / LW30 / NB / Stainless steel / GS / 480

Product codes with output options

1.2W LED at 350mA	LD43DR-350
1.7W LED at 500mA	LD43DR-500
2.4W LED at 700mA	LD43DR-700

LED colour options

LED colour options	Suffix
Super Warm White (2200K)	/LW22
Extra Warm White (2700K)	/LW27
Warm White (3000K)	/LW30
White (4000K) - on request	/LW40
Cool White (5000K)	/LW50
Blue	/LB
Green	/LG
Red	/LR
Amber	/LA

*Other LED colour temperatures are available. Please speak to a member of our sales team.

Beam / lens angle options

12° narrow spot	/NB
-----------------	-----

Bezel finish options

Stainless steel 316
 Polished and passivated stainless steel (for marine environments)
 Flamed solid bronze (antique finish)
 Paint finish white / black / RAL (not suitable for high traffic areas)

*See our finishes guide for other options

Accessories

Glare shield	/GS
--------------	-----

Fixing options

Spring clips	/SC
First fix sleeve and O-rings	/480
Ground tube	/480GT

Use with 350mA, 500mA or 700mA constant current LED drivers

We have a wide range of dimmable LED drivers, 1-10V, DMX, DALI and Mains dimmable. Please see the downloads section on our website:

To run 1-14 LD43DR-500 in series use a TXDEL500D (0-10V dimmable)

To run 1-13 LD43DR-700 in series use a TXDEL700D (0-10V dimmable)